



16 GAUGE STAINLESS STEEL

# FIVE STATION FLOOR MOUNTED SQUARE CORNER SINK WITH TUBULAR LEGS TOE-PUSH OPERATED



Item #:	Qty #:
Model #:	
Project #:	



Foot Valves  
Included On All  
"FV" Models



### FEATURES:

- 8 1/2" high backsplash.
- 8" sink bowl depth.
- Three stainless steel "Z" brackets.
- Two **K-6** 3 1/2" rear basket drains.
- Tubular stainless steel legs with flanged feet.
- One stainless steel support shelf with rear turn-up.
- Toe-Push Operated:** Includes five **K-104** toe-push valves & five **K-121** spouts.

### CONSTRUCTION:

All TIG welded.  
Welded areas blended to match adjacent surfaces and to a satin finish.

### MATERIAL:

All 16 Gauge type "304" stainless steel.  
1 5/8" tubular "304" stainless steel legs.  
Stainless steel gussets.

### MECHANICAL:

Single faucet hole punched at each station.

Model #	Length	# of Spouts	# of Pedals	Wt.	Cu.Ft.
19-FM-100FV	100"	5	5	250 lbs.	35

[Click Here For Install Guide](#)



## MULTI-STATION ACCESSORIES & REPLACEMENT PARTS

Model	Description	QTY:
K-6	3 1/2" Drain (1 1/2" I.P.S.)	_____
K-06	Splash Mount Faucet Mounting Kit	_____
K-13	Stainless Steel Soap Dispenser (Wall Mount Only)	_____
K-104	Toe-Push Valve Assembly	_____
K-121	Single Hole, Splash Mounted 3-1/2" Gooseneck Spout	_____
K-411	Strainer Plate for 3-1/2" Drain	_____
K-508	Special Sizing Charge ( <i>Larger Size Cut Down To Smaller Size</i> )	_____
TA-19	Adjustable Stainless Steel Flanged Bullet Foot	_____



K-121



K-104



K-13



K-411



TA-19

K-06

= Ships UPS

Standard Faucets conform to NSF 61 Standard 9 and compliance to AB 1953 Standards.

**WARNING:** Equipment that include faucets on this page may contain a chemical known to the State of California to cause cancer, birth defects or other reproductive harm.



Customer Service Available To Assist You **1-800-645-3166** 8:30 am - 7:00 pm E.S.T.

For Orders & Customer Service:

Email: [customer@advancetabco.com](mailto:customer@advancetabco.com) or Fax: 631-242-6900

For Smart Fabrication™ Quotes:

Email: [smartfab@advancetabco.com](mailto:smartfab@advancetabco.com) or Fax: 631-586-2933

# DETAILS and SPECIFICATIONS

TOL ± .500"

ALL DIMENSIONS ARE TYPICAL

19-FM-100FV

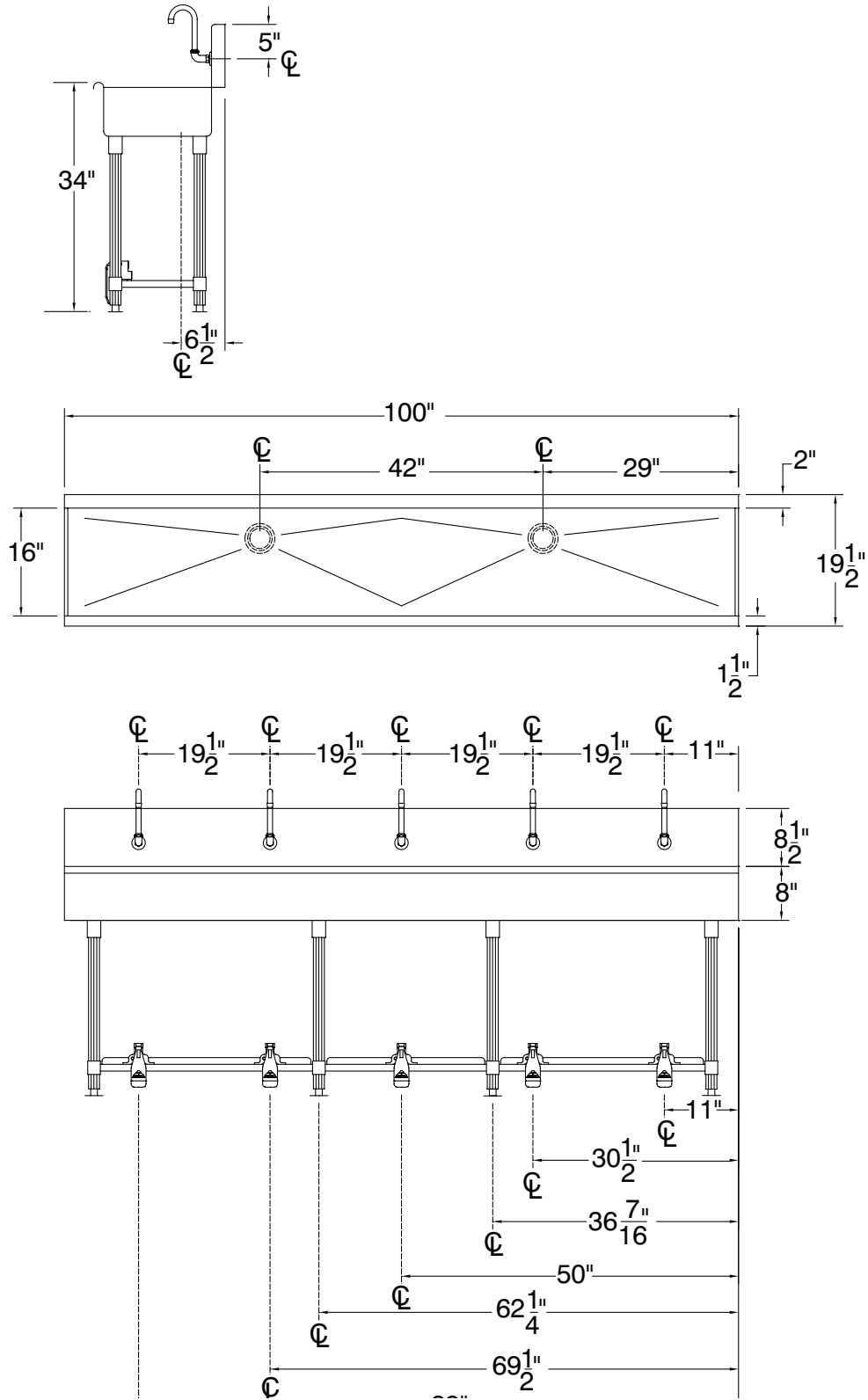

250 Lbs.

